

Série 25CO

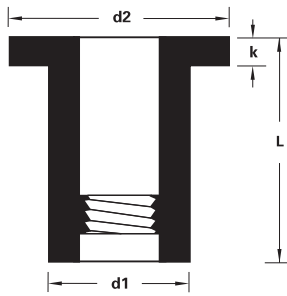

MATERIÁL	POVRCH
PRYŽ (závit mosaz)	-

- PLOCHÁ HLAVA

- VÝHODY:

- montáž bez nýtovačky
- tlumí vybrace
- do všech materiálů
- odolné proti korozi
- elektricky nevodivé
- rozebíratelný spoj

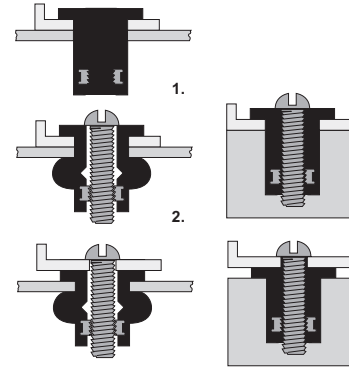

MATICE - PRYŽOVÉ

Všechny rozměry v mm.

		L		Objednací číslo
M3	Ø : 8.3	12.6	0.4- 4.0	25M03CO040
	d1 Ø : 7.9			
	d2 Ø : 11.0			
	k : 1.4			
M4	Ø : 8.3	12.6	0.4- 4.0	25M04CO040
	d1 Ø : 7.9			
	d2 Ø : 11.0			
	k : 1.4			
M5	Ø : 9.9	14.1	0.4- 4.9	25M05CO049
	d1 Ø : 9.6	21.5	4.0-11.6	25M05CO116
	d2 Ø : 12.7-14*	26.1	7.9-16.0	25M05CO163
	k : 0.9-1.3*	39.8	20.5-30.0	25M05CO300
M6	Ø : 13.0-13.3*	16.0	0.4- 2.8	25M06CO028
	d1 Ø : 12.7-13.0*	21.1	0.8- 4.7	25M06CO047
	d2 Ø : 16.0-19.1*	26.7	6.4-11.5	25M06CO110
	k : 1.3-4.75*	35.0	11.5-23.0	25M06CO230

		L		Objednací číslo
M8	Ø : 16.2-18.3*	18.3	0.4- 4.0	25M08CO040
	d1 Ø : 15.9-18.0*	27.9	3.9- 9.5	25M08CO095
	d2 Ø : 20.0-22.1*	50.0	15.0-39.0	25M08CO390
	k : 1.6-5.72*			
M10	Ø : 20.3	55.0	19.0-40.0	25M10CO400
	d1 Ø : 20.0			
	d2 Ø : 22.5			
	k : 1.3			
M12	Ø : 24.3	80.0	38.0-64.0	25M12CO640
	d1 Ø : 24.0			
	d2 Ø : 27.0			
	k : 1.3			

* označené rozměry se liší pro jednotlivé délky pryžových matic a pohybují se v uvedeném rozmezí

Série 29M

MATERIÁL	POVRCH
OCEL	POZINKOVÁNO

- NÝTOVACÍ ŠROUBY

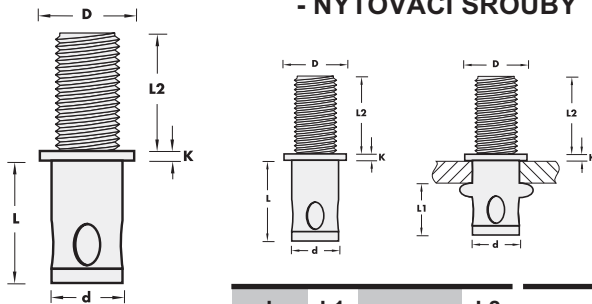

Všechny rozměry v mm.

		L	L1	L2	Objednací číslo	
M4	Ø : 5.5	8.5	4	0.5- 2.0	10	29M042010
	d Ø : 5.4	8.5	4	0.5- 2.0	15	2015
	D Ø : 8.0	9.5	4	2.0- 3.0	10	3010
	k : 0.5	9.5	4	2.0- 3.0	15	3015
M5	Ø : 6.6	10.0	5	0.5- 2.0	10	29M052010
	d Ø : 6.5	10.0	5	0.5- 2.0	15	2015
	D Ø : 9.0	11.0	5	2.0- 3.5	10	3510
	k : 0.8	11.0	5	2.0- 3.5	15	3515
M6	Ø : 7.8	11.0	6	0.5- 2.5	10	29M062510
	d Ø : 7.7	11.0	6	0.5- 2.5	15	2515
	D Ø : 10.0	12.5	6	2.5- 4.0	10	4010
	k : 1.0	12.5	6	2.5- 4.0	15	4015
M8	Ø : 9.9	14.0	8	1.0- 3.0	15	29M083015
	d Ø : 9.8	14.0	8	1.0- 3.0	20	3020
	D Ø : 12.0	16.0	8	3.0- 5.0	15	5015
	k : 1.5	16.0	8	3.0- 5.0	20	5020

NÝTOVACÍ ŠROUBY